

Research ball-cutter "S" shaped blade curve model

Yu Yun, Huang Lixin

Mechanical Engineering College, Shanghai University of Engineering Science Shanghai, 201620, China

Abstract: *Under comparison and understand the grinding motion analysis under the cutting edge model and generalized helical motion of tool general advantages and disadvantages, on the basis of the knife-edge model using spiral movement curve of physical motion, such as integrated spiral Angle and the characteristics of spiral mathematical model under the lead of, put forward the mathematical model of a new type of spiral cutting edge is used to study the "S" shape of the ball head milling cutter blade cutting edge curve forming mechanism.*

Keywords: *Ball end milling cutter A cutting edge model*

I. Introduction

Curve Ball cutter blade design is crucial, Blade not only determine ball-cutter geometry, but also determines the shape of the machined surface (molding milling), and for cutting, ball milling workpiece quality plays an important role. "S" type spiral blade can change the flow of the chips, the chips flowing along the spiral groove, so easy to heat, reducing the milling resistance, effectively preventing the chip scratch the machined surface; Meanwhile helix angle also makes the actual ball milling cutter rake angle is increased, improving the sharpness of the cutting edge, which greatly improves the processing quality, and enhance the effectiveness of the tool to use. Establishing ball mill cutting edge mathematical model of "S" shaped blade ball cutter geometry analysis and optimization, milling mechanism, choice of cutting edge sharpening parameters, and cutter wear failure analysis are analysis has a strong theoretical guidance significance.

Chinese and foreign scholars have done a lot of research of "S" type cutting edge curve. Yi De Ming and others on the basis of analysis of ball cutter grinding method, established a "S" shaped blade before the ball cutter, flank and cutting edge mathematical models^[1]. He Yao Xiong et according to the geometric characteristics of rotary cutting tool, proposed the concept of generalized helical motion,. And apply the concept of the establishment of a ball head cutter blade curve of typical general mathematical model . And for some of the special properties of the blade curve and ball end cutter blade distribution requirements, puts forward the concept of transition blade and its design method^[2]. Hu Si Jie et People on the basis of the mathematical model has been established, according to the modeling method of grinding, grinding parameters and structure parameters was deduced and the relation between the design parameters; Analyses the grinding parameter change on the influence of design parameters^[3]. Y. Altıntaş, S. Engin established mathematics model helix spiral corner cutter head, based on the definition of the helix angle of the blade was designed and analyzed the ball-cutter blade spiral helix angle of equal When grinding and cutting^[5,6]. SK Kang, KFEhman et proposed a mathematical model of the tool spiral groove surface, and through the ball-cutter grooves truncate the study obtained their processing methods^[7]. Yucesan et built before the ball milling cutter head, the sword of the

differential equation, after cutting area and cutting tool based on the positive pressure before and after the knife surface equation of milling force and friction force, calculating the function of various micro yuan blade in the process of milling vector, and concluded that the shear force coefficient, plough in equation force coefficient can be calculated according to the cutting test data, etc^[8,9]. S.Jain S.J ain assumption in micro cutting blade of yuan in 2 d coordinates for the orthogonal cutting, studied the ball milling cutter head of cutting parameters, analyzes the method of cutting tool to the cutting edge in the cross section shape, another kind of method to compute the milling force is put forward ^[10].

II. Propose a new ball mill cutting edge curve model

Ball end milling cutter is a kind of complex rotary blade cutting tools, grinding and manufacturing difficulties, there are many factors affecting the effect of blade shape design. Many Chinese and foreign scholars have done a lot of research work on cutting edge model, Now more common are mainly under the grinding motion analysis of cutting edge model^[1,3], under the generalized helical motion of cutting tool gm knife-edge model^[2], spherical and space spherical composite blade curve equation and the intersection of^[4], etc. The mathematical model of cutting edge, has strong theoretical guidance significance to edge of "S" shape ball head geometric parameter analysis and optimization of the milling cutter, milling processing mechanism, the selection of cutting blade sharpening parameters and cutter wear failure research analysis. In comparison and understand the cutting edge model in the case of grinding motion analysis and general spiral motion of the cutting tool general advantages and disadvantages on the basis of the knife-edge model. using spiral movement curve of physical motion, such as spiral Angle and the characteristics of spiral mathematical model under the lead of, put forward the mathematical model of a new type of spiral cutting edge is used to study the "S" shape of the ball head milling cutter blade cutting edge curve forming mechanism.

2.1 "S" shaped blade sharpening mathematical model based on motion analysis established

Grinding motion analysis under the "S" blade of mathematic models, deduced the ball head milling cutter grinding parameters, namely for the mechanization of the milling cutter grinding and design from the Angle of the grinding production provides the basis of theoretical analysis, as well as for ball end milling cutter geometrical parameters provide a basis for the optimization design. But the ball milling cutter head too many influence factors in the process of grinding, grinding parameters needs to be further analysis and optimization.

2.1.1 Spherical ball milling and grinding forming the front and rear flank

B Ball end milling cutter cutting edge grinding main points mainly two parts grinding groove, deputy groove, contains the rake face, the first after face, after the second knife face, let crumbs slot, etc. Grinding wheel grinding ball milling cutter head of trajectory motion and relative motion of the milling tool's blank forming contour surface, enveloping surface of grinding wheel which is a ball head milling cutter knife surface before and after the knife surface. Ball end milling cutter with ball head part modeling process should be "S"

shape blade grinding method is the same. Under the precondition of spiral groove has been processed, the "S" shape of the ball head milling cutter blade sharpening consists of spherical, knife before and after the knife surface composed of three parts. "S" shape ball head each surface grinding forming milling cutter movement is shown in figure 1.

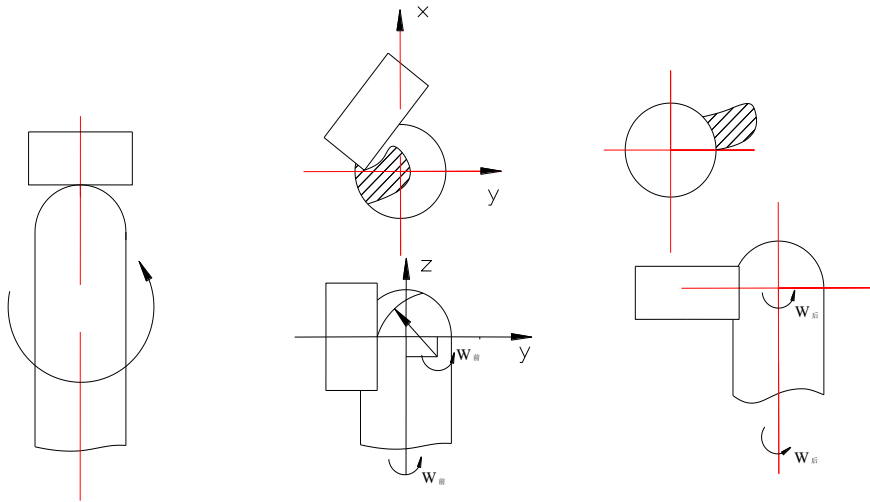

figure 1.1.1 Spherical shaped motion Rake forming movement Flank forming movement

Spherical shape is simpler, forming principle, as shown in the figure first fixed position of grinding wheel, ball milling cutter head was spinning around the globe, milling cutter is rotating around its own axis.

On the surface of the knife before forming movement to conform to the processing conditions on the basis of the same meet the design requirements. Therefore, the deflection of grinding wheel in the vertical plane first an Angle of ρ_1 , specific size according to the requirement of the cutting tool rake Angle. In the initial position, grinding wheel along the ball milling cutter head of radial feed a week tooth the tooth depth. Milling cutter with $K_1\omega_1$ around its own axis rotation angular velocity, at the same time the ball milling cutter head with angular velocity ω_1 rotate counterclockwise around the rotary center. Its rotary center cutter eccentricity is $\sqrt{L^2 + H^2}$.

Movement with the knife surface after forming the surface to meet the demands of the posterior horn, on the other hand also requires blade sharpening after cutting edges and rake face of cutting edges after grinding, collocated.

As shown in figure 1, to meet the demands of the posterior horn, also need to adjust grinding wheel, the axis of the grinding wheel and the cutter axis have a height difference of h . Ball end milling cutter with $K_2\omega_2$ around its own axis rotation, at the same time with angular velocity ω_2 turning counterclockwise around the globe O level. To ensure that the resulting "S" grinding cutting edges and rake face of cutting edges after grinding, collocated, $K_1\omega_1$ and $K_2\omega_2$ has certain function relation^[1] $\omega_2=f(\omega_1)$, $K_2=f(K_1)$.

1.1.2 A mathematical model of cutting edge grinding parameters

Set up by the previous forming on the surface of the knife after sports centre O as the origin of the

coordinate system is shown in figure 2. Before the grinding parameters for the position of the adjusting parameter for R_1 、 H 、 L 、 ρ_1 , motion parameters for K_1 、 ω_1 ; After the position adjustment of parameters for h , motion parameters for K_2 、 ω_2 . According to the mathematical formula reasoning can be as follows [3]:

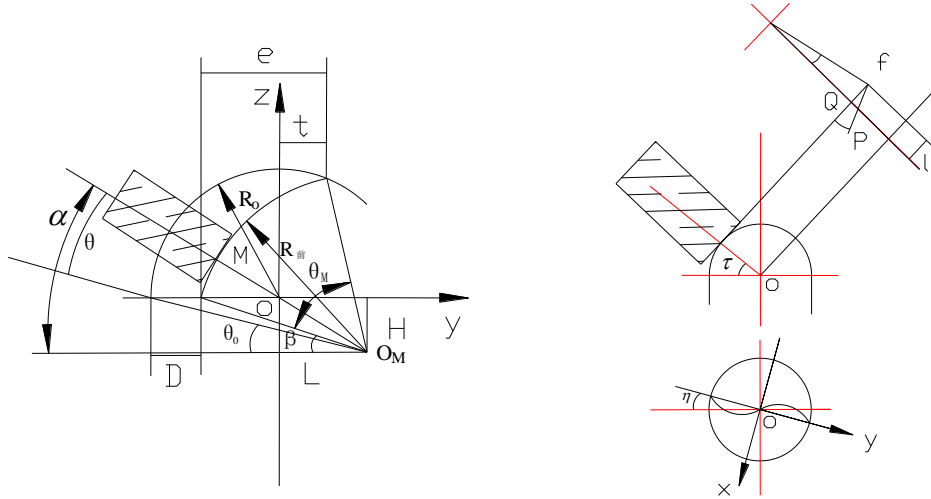

Figure 1.1.2 Before and after grinding of the parameters for analysis

$$R_1 = \frac{\sqrt{R_0^2 - t^2 + e^2}}{2 \sin \frac{\theta_m}{2}}, \tag{1}$$

$$H = R_1 \sin (\beta + \theta_m) - \sqrt{R_0^2 - t^2}, \tag{2}$$

$$L = R_1 \cos (\beta + \theta_m) + t, \tag{3}$$

Annotation: e : Offset parameters $e = R_{前} - D + t$

$$\beta: \text{ Angle parameter } \beta = \frac{\pi - \theta_m}{2} - \arctg \frac{\sqrt{R_0^2 - t^2}}{e}$$

R_0 : Ball milling radius;

D : Cutter tooth week quantity;

t : Ball entered the blade open axis line width, the value associated with the ball head milling cutter radius as follows [7].

When $R_0 \leq 6$, $t = 0.2 R_0$,

$6 < R_0 \leq 12$, $t = 0.15 R_0$,

$12 < R_0$, $t = 2 \sim 2.5 \text{mm}$;

θ_m : Rotation arc angle, take $\theta_m = 45^\circ \sim 47^\circ$;

$R_{前}$: Rotation arc radius;

H, L : Globe rotation center O of the machine O_M offset.

Shown in figure 1 knife before forming movement "S" shape which is formed by the edge curve parameter equation is as follows [1]:

$$\begin{cases} X = R_0 \cos \delta \sin \varphi \\ Y = -R_0 \cos \delta \cos \varphi \\ Z = R_0 \sin \delta \end{cases} \quad (4)$$

$$\text{Annotation: } \delta = \alpha + \arcsin \left[\frac{\sqrt{H^2 + L^2} \sin(\alpha - \arctg(H/L))}{R_0} \right]$$

$$\varphi = K_1 \theta$$

$$\alpha = \theta_0 + \theta$$

Since its introduction in the same way, on the surface of the knife cutting edges are formed by building motion parameter equation is as follows ^[1]:

$$\begin{cases} X = R_0 \cos \tau \sin \eta \\ Y = -R_0 \cos \tau \cos \eta \\ Z = R_0 \sin \tau \end{cases} \quad (5)$$

Annotation: τ for milling around the X axis Angle, η for milling around the Z axis Angle

Before and after grinding knife surface formed by the two edge curve to overlap, the parameter equation is asked to parametric equation (4) and (5) there is a certain relationship, make the curve of both said. By the literature [3] knowable and function relation between and the relation between the same:

$$\delta = \theta_0 + \frac{\varphi}{K_1} + \arcsin \left[\frac{\sqrt{H^2 + L^2} \sin \left(\theta_0 + \frac{\varphi}{K_1} - \arctg(H/L) \right)}{R_0} \right] = f_1(\varphi) \quad (6)$$

1.2 General mathematical model of knife edge under the generalized spiral motion

General mathematical model of the tool blade from the rotary knife edge curve view, the use of generalized spiral motion concepts easy to understand. But it ignored the nature and distribution of some special requirements for ball-shaped cutter blade.

1.2.1 Generalized spiral movement principle

Ball end milling cutter is a kind of typical rotary cutting tool, curve and curved surface on the rotary cutter can often spiral, spiral surface is used to describe and analysis. Helical and spiral surface is a point in the space coordinate system respectively, formed by a spiral motion curve do curve and curved surface. Generalized helical motion is a point in space at any movement on the surface of the rotary. The movement can be divided into orbit around the rotation of the rotating shaft and the movement of the bus along the rotary surface, at the same time, the bus along the rotary surface movement and can be decomposed into the axial and radial motion movement. A generalized helical motion, the velocity vector v around the rotating shaft rotational velocity

vector v_ω , generatrix direction along the rotary surface of mobile linear velocity vector for v_s , axial velocity vector for v_a , the radial velocity vector for v_r , then^[2]

$$v = v_\omega + v_s = v_\omega + v_a + v_r \tag{7}$$

It found that generalized spiral motion is based on the traditional helical cylindrical spiral movement and then superimposed on a radial motion.

1.2.2 Ball knife edge curve general mathematical mode

Rotary cutting tool ball head milling cutter cutting edge is located in the rotary surface, and are back in the manufacturing process of axis of rotation. Any curve surface of revolution is bus (space), formed by the rotating around a fixed axle surface, as shown in figure 1.2.2, according to the fixed axis x, busbar initial position for the plane XOY plane building space coordinate system and a curve equation for $f = f(x)$, at any time of plane curve rotation Angle is theta, the rotary surface can be expressed as^[2]

$$r(x, \theta) = [x, f(x)\cos\theta, f(x)\sin\theta]^T \tag{8}$$

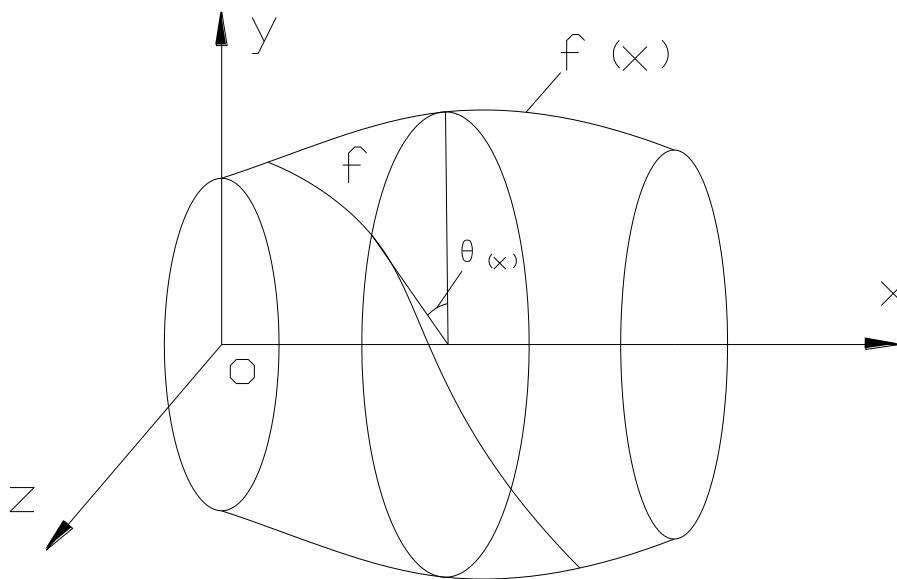

Figure 1.2.2 Universal model rotating tool

Rotary cutting tool is located in the tool rotary cutting edge curve surface, the surface of revolution in the model, just make sure the rotation Angle θ and x as a function of $\theta = \theta(x)$, can determine the cutting edge curve of rotary cutting tool, namely^[2]

$$r(x, \theta) = r(x, \theta(x)) = [x, f(x)\cos\theta(x), f(x)\sin\theta(x)]^T \tag{9}$$

For ball end milling cutter, a ball head of radius r, and is formed by ball head rotary surface generatrix is $f(x) = \sqrt{r^2 - x^2}$, To get the ball head tool cutting edge curve of general mathematical model for:

$$r(x, \theta) = \left[x, \sqrt{r^2 - x^2} \cos \theta(x), \sqrt{r^2 - x^2} \sin \theta(x) \right]^T \quad (10)$$

III. The new ball-cutter helical cutting edge mathematical model

2.1 New model of the ball head milling spiral cutting edge ideas put forward

Integral curve of cutting edges of ball end mill for the traditional cylindrical spiral curve, the formation of its trajectory can be decomposed into two curve motion synthesis, Compared with the general mathematical model of rotary cutting tool^[2], without regard to the radial motion. As shown in figure 3, for ball end milling cutter axis Z axis, with ball head milling cutter base circle for origin O, floor space coordinate system is established with the plane XOY, set on the bottom circle move with angular velocity omega point $\omega(t)$ in XOY plane do circular motion around the center of the circle, at this time for it to a vertical velocity $v_z(t)$, and the fixed point M will be in v has risen in a spiral of speed, on the surface of the rotary speed v is $R_0\omega(t)$ and $v_z(t)$ synthesis.

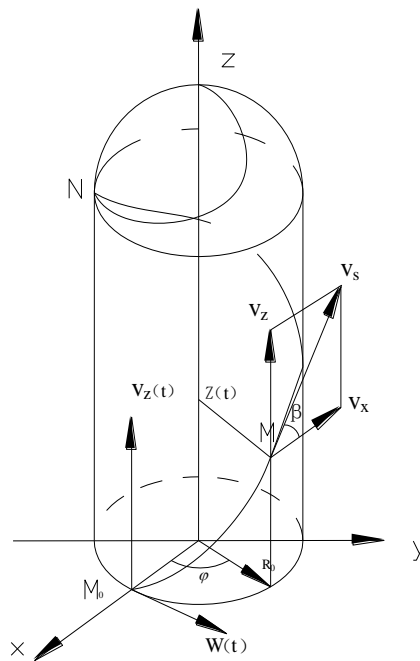

Figure 3 Spiral motion diagram

With figure 3 can be fixed point M trajectory equation is as follows:

$$\begin{cases} X = R_0 \cos \varphi(t) \\ Y = R_0 \sin \varphi(t) \\ Z = Z(t) \end{cases} \quad (11)$$

Annotation: $\varphi(t)$ for fixed point M in XOY plane turning in the process of spiral Angle;

Z (t) for fixed point M has risen in a spiral process in $v_z(t)$ under the action of the height of the rise;

R_0 for ball end milling cutter radius.

$$\begin{cases} \varphi(t) = \int_0^t \omega(t) dt \\ Z(t) = \int_0^t v_z(t) dt \end{cases} \quad (12)$$

Into the equation 11

$$\begin{cases} X = R_0 \cos \int_0^t \omega(t) dt \\ Y = R_0 \sin \int_0^t \omega(t) dt \\ Z = \int_0^t v_z(t) dt \end{cases} \quad (13)$$

$\Omega(t)$ and $v_z(t)$ are based on t arguments for function, is used to control the fixed point of spiral trajectory. For some cutter blade special qualities and distribution requirement, can be combined with the computer using the mathematical method of analytic geometry optimization $\omega(t)$ and $v_z(t)$, from the cutting blade comply with the design requirements.

2.2 Such as lead (such as spiral Angle) cylindrical blade curve mathematical model

Ball end milling cutter cylinder helix lead helix "such as" and "such as spiral Angle spiral" two kinds^[2]. Though practice medium spiral Angle of cutting edge cutting tool cutting performance is superior to lead the cutting edge of cutting tool, but in the actual tool manufacturing process, a lot of knives took the form of "lead", such as processing. Do generalized helical motions of rotating shaft rotate a week, a point on the projection of mobile distance, called generalized helical motion of lead. When the fixed point M spiral movement of the axial velocity $v_z(t)$ and the ratio of angular velocity $\omega(t)$ for the fixed value, the formation of the spiral trajectory (blade curve) is the lead, such as the blade curve. Ball for when lead helical blade curve, change of each point on the ball milling blade Angle is, the flow of chip along the edge direction and also for the change. $v_z(t)$ and the ratio of $\omega(t)$ is essentially rotating units radian, fixed point M projection on the rotating shaft to move distance, called the induced lead. Lead to P_z induction, know:

$$p_z = \frac{V_z(t)}{\omega(t)} = \frac{\frac{dz}{dt}}{\frac{d\varphi}{dt}} = \frac{dz}{d\varphi}$$

Accordingly, $d\varphi = \frac{dz}{p_z}$, which is $\varphi = \varphi_0 + \frac{z}{p_z}$, Put this type of plug (11) on the cylinder can

be induced lead to P_z lead, such as ball head milling cutter blade curve model:

$$r(z) = \left[R_0 \cos\left(\varphi_0 + \frac{z}{p_z}\right), R_0 \sin\left(\varphi_0 + \frac{z}{p_z}\right), z \right]^T \quad (14)$$

Do spiral movement of the fixed point M, if at any instant, the velocity V_s and along the axis of the direction of the spiral movement speed v_x keep constant value Angle, formed by the fixed point M mobile trajectory (blade curve), referred to as the spiral Angle of the blade curve, etc. Blade spiral Angle can obviously improve the milling cutter of continuous cutting, control chip flow direction. Tool has a lot to do with the shape of the spiral Angle of the blade, increase the spiral Angle can improve the actual cutting of the cutting tool rake Angle, fully play the advantages of cutting of Angle, both reduced the milling impact and chip deformation, reduce energy consumption, improve the quality of processing surface, reduce the degree of tool wear. The spiral Angle is set to β , as shown in Figure 3:

$$\tan\beta = \frac{v_z}{v_x} = \frac{v_z(t)}{R_0\omega_x(t)} \quad (15)$$

By (10), if the β for the fixed value, $\frac{v_z(t)}{\omega_x(t)}$ as constant value, Ball head milling cutter on the cylinder is consequently "such as spiral Angle spiral" to lead helix "wait". Weeks with the ball milling blade should be in the transition smooth connection, the ball head spiral in abundance point Q of the spiral Angle of blade and blade spiral Angle should be equal.

IV. Conclusions

From analyzing the "S" shape of ball head milling cutter blade curve model, Shape and the cutter blade spiral Angle, increase the spiral Angle can improve the tool before actual cutting corner, effectively realize the advantages of oblique cutting, reduce milling impact and chip deformation, reduce energy consumption, improve the quality of processing surface, reduce the tool wear. And lead such as ball blade curve of helix, the blade Angle of the ball on the edge of each point is different, the flow of chip is change along the direction of the ball milling, die steel milling process, the temperature of cutting zone is higher, in order to avoid because of chip removal and produce adhesive tool breakage, the phenomenon such as surface burning, cutting tool spiral Angle design should be between 30 to 45 °.

References

- [1] Yi Deming, Liao Gang, Long Meibiao Lin Cheng, Yang by chapter. "S" shape edge of ball end mill research (I) - mathematical model [J]. Journal of Hunan university, 1996.23 (2) : 65-69
- [2] He Gaoxiong, Zhou Yunfei, Zhou Ji. Cutter blade modeling and transitional blade design. Journal of mechanical engineering [J]. 2001.37 (9) : 101-104
- [3] Hu Sijie, Liao Gang, Yi Deming, Yang Shouzhang. "S" shape edge of ball end mill research (III) - grinding parameter analysis [J]. Journal of Hunan university, [6] 1996.23:71-77

- [4] Pang Siqin, Qiao Xiaofeng, Wang Xibin, Peng Song. A ball milling cutter head "S" shape of blade curve of the mathematical modeling method [J]. Journal of Hunan university, 2014.41 (5): 44-49
- [5] ENGIN S, ALTINA Y. Mechanics and Dynamics of General Milling Cutters [J]. Part I: Helical End Mills. Int. J. Mach. Tools. Manu fact, 2001, (41): 2195-2212.
- [6] ALTINTA Y, ENGIN S. Generalized Modeling of Mechanics and Dynamics of Milling cutters [J]. Annals of the CIRP . 2001, 50(1) : 25-30.
- [7] KANG S K, EHMANN K F . A CAD Approach to Helical Groove Machining Mathematical Model and Model Solution [J]. International Journal of Machine Tools & Manufacture , 1996, 36(1) : 141-153.
- [8] YUCESAN G, ALTINAS Y. Mechanics of Ball-Nose End Milling Process [J]. ASME Journal of Manufacturing Science and Engineering, 1993, 115(4): 543-551.
- [9] YUCESAN G, ALTINAS Y. Improved Modeling of Cutting Force Coefficients in Peripheral Milling [J]. Int . J. Mach. Tools Manuf, 1994, 34: 473-487.
- [10] JAIN S, YANG K C. A Systematic Force Analysis of the Milling Operation [J]. Proceedings of ASME Winter Annual Meeting, San Francisco, 1989: 55-63.